

Thermal Analysis of Acrylonitrile/Acrylic Acid Copolymer Dendrigrated with Citric Acid

Somaye Akbari, Mohammad Haghghat Kish, Mohammad Karimi, and Ali Akbar Entezami

Abstract—Thermal analysis of acrylonitrile/acrylic acid P(AN/AA) copolymer films containing 5%, 10% and 20% acrylic acid dendrigrated with citric acid (CA) is examined using differential scanning calorimetry (DSC) with various heating rates, thermogravimetry (TGA) and derivative thermogravimetric analysis (DTG). Also, the effect of carboxylic acid on thermal stabilization of the P(AN/AA) copolymers, when the carboxylic acid groups are in the bulk and when they are on the surface of the films dendrigrated with CA, were studied using FTIR analyses.

It is demonstrated that inclusion of carboxylic acid considerably enhances the rate of thermal degradation. The apparent activation energy (E_a) for overall cyclization and oxidation reactions is calculated using Kissinger's method. The results reveal that carboxylic acid, when used as a dendrigraft, influences the cyclization and oxidation process in a different way in comparison with when they are in the bulk. The activation energy of the first generation dendrigrated P(AN/AA) copolymer was lower than that of the copolymer and the fourth dendrigraft generation.

Keywords: acrylonitrile/acrylic acid copolymer, activation energy, dendrigraft, stabilization, thermal analysis

I. INTRODUCTION

Thermal behavior of polyacrylonitrile (PAN) and its copolymers has been studied extensively by a number of researchers because of their wide applications in textile industry and in high performance carbon fiber productions [1-4]. Mainly due to the unacceptable properties of PAN homopolymer, using small amounts of acidic co-monomers facilitates its processing and broadens its applications [5-8].

By heating PAN homo and copolymers above 39°C, the materials initially undergo a number of transitions, then at about 150 °C thermal instabilities begin. Using conventional techniques, PAN homo and copolymers do not show a melting point due to their tendency for degradation before melting [9-11]. The lack of melting point is attributed to the structure adopted by the polymer chains and the interactions between the pendant nitrile groups originated from the asymmetry of electrons arrangement in the C≡N group in a moderately strong electrical interaction. For temperatures above 150 °C, PAN and its copolymers undergo a number of chemical and

physical changes including shrinkage, cyclization, dehydrogenation, oxidation, cross-link formation, and fragmentation [1-3,12].

PAN and its copolymers in the thermal stabilizations temperature range ($\approx 150-300^\circ\text{C}$) undergo certain reactions resulting in ensuing prominent DSC exothermic curves [13-15]. These reactions lead to formation of an infusible stable ladder structure (cyclization) [16]. In the presence of air, these reactions show much broader exotherms compared to those that occur in the presence of inert atmosphere which exhibit doublet peaks. It is believed that the large primary peak in the air atmosphere is the result of both cyclization and oxidation reactions [17-20] while the single DSC peak observed in nitrogen atmosphere is mainly due to the cyclization reaction. Furthermore, several authors have reported that the inclusion of acidic comonomer facilitates the exothermic reaction during thermal stabilization [7,21]. Consequently, the effects of acrylic, methacrylic, and itaconic acid on the cyclization process have also been examined by some investigators [22-23]. The findings revealed that when the acidic content increase, the exotherm becomes less intense. In addition, the initiation of the exotherm peak starts at a lower temperature due to cyclization through a radical mechanism for PAN homopolymer, while in the presence of acidic co-monomer the cyclization initiates through an ionic mechanism. The findings revealed that when acidic content increase, the exotherm becomes less intense and the lower broader initiation peak due to the cyclization through a radical mechanism for PAN homopolymer, while in the presence of acidic co-monomer the cyclization initiates through an ionic mechanism [7,22].

There are other methods for thermal modification of PAN-based carbon fibers; for instance, polyacrylonitrile was modified with ammonium itaconic acid via copolymerization [24]. The influence of surface modification of acrylic copolymer on the thermal stabilization and degradation is concerned in the present work. Among various modifications, the dendrigraft structure is considered as a class of highly branched macromolecules belonging to the dendritic polymer family [25]. Hyperbranched polymers including dendrimers have recently attracted special interest because of their great potential in a number of applications resulting from high degree of chemical functionality, precise molecular sizes, and the presence of nano-scale cavities within their structures [26-28].

In the previous works [29-31], the formation of citric acid (CA) dendrigrated on the P(AN/AA) samples

S. Akbari, M. Haghghat Kish, and M. Karimi are with the Department of Textile Engineering, Amirkabir University of Technology, Tehran, Iran. A. A. Entezami was with the Faculty of Chemistry, University of Tabriz, Tabriz, Iran. He passed away on July 11, 2015. Correspondence should be addressed to S. Akbari (e-mail: Akbari_s@aut.ac.ir)

TABLE I
COMPOSITION OF P(AN/AA) COPOLYMER FILM AND THE PERCENTAGE OF CONVERSION OF DENDRIGRAFTED CA ON THE FILM WITH 10 % AA

Polymer	Sample Abbreviated Name	Comonomer in the feed (mol %)	Measured Comonomer polymer content (mol %)	percentage conversion of dendrigrated structure
P(AN/AA) 5% AA	5G ₀	5	6.1	-
P(AN/AA) 10% AA	10G ₀	10	9.4	-
P(AN/AA) 20% AA	20G ₀	20	15.3	-
P(AN/AA) 10% AA First generation	10G ₁	-	-	51.6
P(AN/AA) 10% AA 4 th generation	10G ₄	-	-	1.9

containing various amounts of acrylic acid (AA) in the form of powder, film, wet-spun and electrospun fibers having considerably different specific surface area was examined in detail. The present work deals with the effect of carboxylic acid on the thermal degradation of P(AN/AA) copolymer films in the bulk during copolymerization process as well as thermal degradation of dendrigraft modifications. Furthermore, the apparent activation energies for stabilization reactions are determined by the use of differential isoconversional and Kissinger method from DSC data according to the recommendation results of the ICTAC Kinetics Committee [32-33]. They have mentioned that only multiple temperature program methods should be used for computation of reliable kinetic parameters.

II. EXPERIMENTS

A. Materials

Acrylonitrile (AN) and dimethylformamide (DMF) from Fluka were purified by distillation before use. Sodium metabisulfate, acrylic acid (AA), sodium bicarbonate, citric acid (CA) and dicyclohexylcarbodiimide (DCC) were purchased from Merck (Germany) and used as received. Potassium persulfate from Merck was purified by recrystallization in methanol. 1,4-Dioxane and tetrahydrofuran (THF) were purchased from Lab-Scan and used as received.

B. Preparation of P(AN/AA) Copolymer Film

Dendrigrift was synthesized according to the procedure described in the previous work [29]. In brief, the carboxylic acid of P(AN/AA) copolymer films was activated with DCC in a mixture of THF and dioxane (50:50 v/v) at room temperature for 3 h. The mol fraction of DCC was taken in accordance with the mol fraction of AA in P(AN/AA) copolymer films. The film was then removed and washed with pure dioxane and allowed to hang free at room temperature. The activated samples were then reacted with CA in a mixture of THF and dioxane (50:50 v/v) for 3 h at the temperature of $60 \pm 1^\circ\text{C}$ in order to produce G1 product. In the succeeding reaction, G1 was used to prepare the next product, as designated by G2. The successive compounds, i.e. G3 and G4, were then prepared. The procedures for the next generations were similar to those for G1. The reactions of copolymerization, preparation of the film and the dendrigrift have been explained in detail in previous published works [29,30]. The composition of P(AN/AA) copolymer film, and the

percentage of conversion of dendrigrated CA on the film, and the abbreviated names of the samples are summarized in Table I. Scheme 1 shows the expected form of the first generation number of CA dendrigrated on P(AN/AA) films.

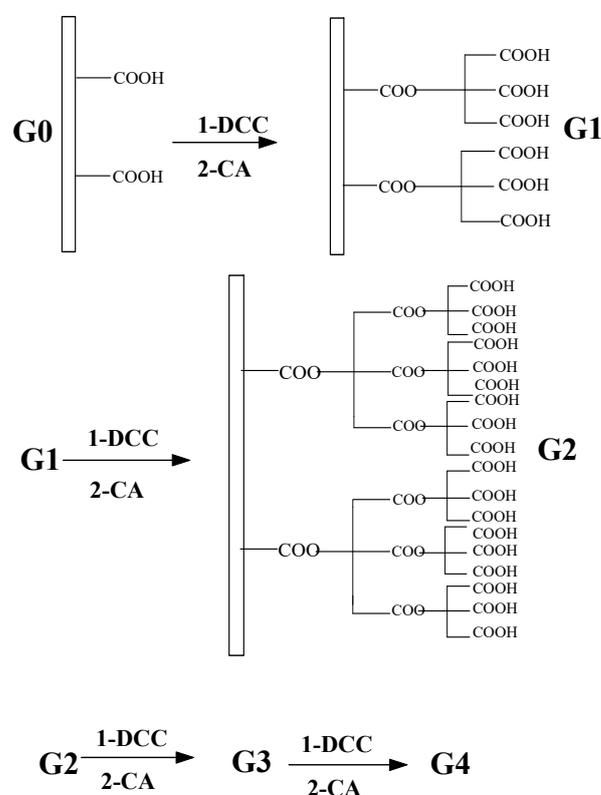

Scheme 1. A schematic of the synthesis of CA dendrigrated on the P(AN/AA) surface.

C. Characterization

Thermal changes of the samples were probed using a differential scanning calorimetry (DSC), (TA Instrument 2010 differential scanning calorimetry, USA). Samples of 1–2 mg were heated up in the aluminum pans from 30 to 400°C with the heating rate of 5, 10 and $20^\circ\text{C}/\text{min}$ under air atmosphere with the flow rate of 40 ml/min. The triple temperature procedures [32] were used to calculate the kinetics.

To be certain of accuracy [33], heating runs were performed on the samples with four different masses (0.5, 1.0, 5.0 and 10.0 mg). It was found that a sample mass of 1–2 mg makes an error of lower than 1°C in the temperature.

Moreover, to avoid any temperature errors regarding to the heating rate, the temperature was calibrated at every used heating rate.

Thermogravimetric analysis measurements of the samples (4–5 mg) were made using a TGA instrument, (PL-1500 instrument, UK) under air and nitrogen atmospheres from 30 to 600°C at a constant heating rate of 5 °C/min.

Fourier transform infrared (FTIR) spectra of films were recorded between 400 and 4000 cm^{-1} using a Nicolet 670 FTIR spectrophotometer in transmission mode. Nominal resolution for all spectra was 4 cm^{-1} , and there were 32 scans for each spectrum. All film samples were heated at 150, 170, 200 and 220 °C in a vacuum oven before being characterized via FTIR instrument.

III. RESULTS and Discussion

A. FTIR Results

The changes of FTIR spectra after dendrigraft formation have been studied in detail in the previous published works [29–31]. It was found that the carboxylic acid groups on the films increased by the increase in the generation numbers, which were depicted by the increase in the intensity of the peaks at 1724 cm^{-1} , which was also confirmed by NMR spectroscopy. In the present work the difference between the inclusion of carboxylic acid in the bulk of P(AN/AA) copolymer produced during copolymerization and the presence of carboxylic acid on the P(AN/AA) surface produced by dendrigraft formation, during thermal degradation is considered.

Fig.1 reveals the changes in the FTIR spectra of a P(AN/AA) film containing 10% AA, 10G0, heated at different temperatures. The characteristic bands appear at 2241, 1724 and 2873 cm^{-1} due to the stretching of $-\text{C}\equiv\text{N}$, $-\text{C}=\text{O}$, CH_2 , respectively. Fig. 1(a) presents the spectrum of P(AN/AA) film before heating and Figs. 1 (b) to 1(e) presents the spectra of the film heated at 150, 170, 200 and 220 °C, respectively. The band at about 1645 cm^{-1} which is assigned to the cyclization of P(AN/AA) in DMF solvent [29–31] is of particular interest. As the heat-treatment temperature increased, the cyclized structure in DMF solvent decreased. The stabilization reactions take place above 170 °C, since no new bands corresponding to them can be found in Figs. 1 (a) to 1(c). When P(AN/AA) was heated to 200 °C as shown in Fig. 1(d), a weak band at 1613 cm^{-1} appeared which is due to the combination vibrations of $\text{C}=\text{C}$ and $\text{C}=\text{N}$ stretching, and NH in-plane bending of the ladder-frame structure of the stabilized P(AN/AA) [5,7], where the cyclization and oxidation reactions started. In addition, the intensity of 2241 cm^{-1} band, assigned to nitrile groups, increased by increasing the temperature above 150 °C. This intensity increase may be due to the elimination of cyclized structure in DMF solvent. Based on the above spectra and with confirmation from literature [1,5,7,22] Scheme 2 is proposed for the ionic mechanism of P(AN/AA) stabilization.

As shown by the authors [5,7,12], the presence of more carboxylic groups such as two carboxylic groups in

itaconic acid compared to one carboxylic group in the other acidic comonomers, provides more opportunities to induce cyclization of the nitrile groups. In the present work the carboxylic acid groups in the bulk and on the surface of the P(AN/AA) copolymer films was increased. Figs. 2 and 3 reveal the changes in the FTIR spectra of P(AN/AA) containing 10% AA dendrigrafted with CA at first (10G₁) and fourth (10G₄) generation numbers, respectively. Figs. 2(a) and 3(a) present the spectra of G₁ and G₄, respectively. Of particular interest is the band at 870 and 1116 cm^{-1} due to the intramolecular hydrogen bonding appearing during modification as well as the band at 1645 cm^{-1} due to the cyclization of P(AN/AA) in DMF solvent, which decreases with increase in the generation number in dendrigraft formation [31]. In addition to the decrease in the intramolecular hydrogen bonding, as the heat-treatment temperature increased, the hydrogen bonding intensity decreased.

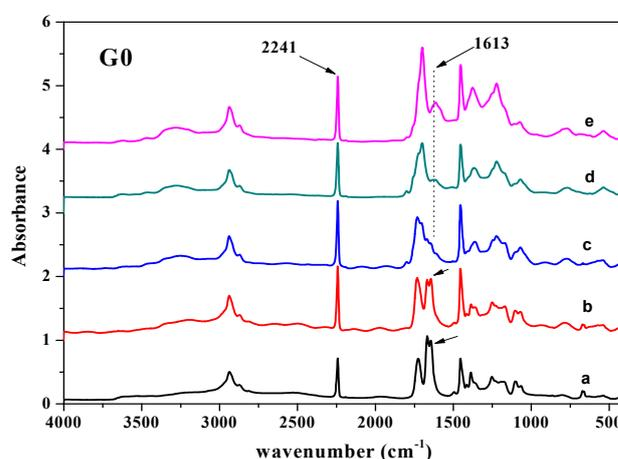
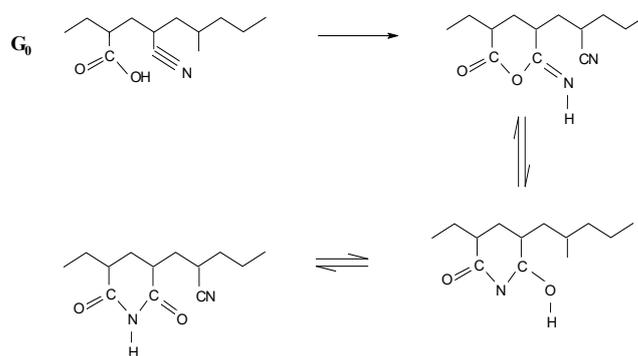

Fig. 1. FTIR spectra of the P(AN/AA) copolymer films containing 10%AA (G0) heated at different temperatures for 10 min: (a)original (not heated), (b) 150 °C, (c) 170 °C, (d) 200 °C, and (e) 220 °C.



Scheme 2. Proposed structure of P(AN/AA) copolymer during thermal stabilization

Similar to G₀, the ladder-frame structure of the stabilized dendrigrafted sample take place above 170°C. The proof of this event is that no new bands at 1613 cm^{-1} can be found in the P(AN/AA) copolymer films dendrigrafted with CA first generation (10G₁) and those heated at different temperatures, Fig. 2(a–c), and also for the fourth generation number (10G₄) heated at different

temperatures, Fig. 3(a-c). In the meantime, the weak shoulder at 1801cm^{-1} above 170°C possibly indicates the formation of anhydride rings; it is shown in Scheme 3. By increasing generation numbers, the 1613cm^{-1} band continues to grow which means cyclization and oxidation have been promoted by the inclusion of carboxylic acid groups on the surface. However, it is hard to establish the exact mechanism of stabilization only with the present FTIR spectra.

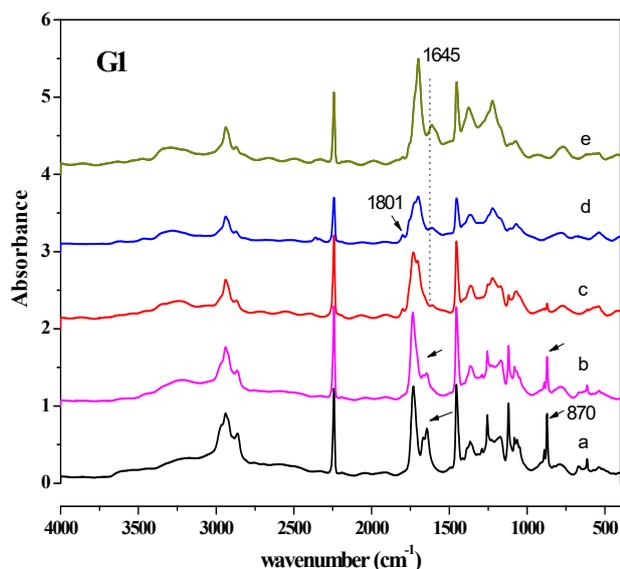

Fig. 2. FTIR spectra of the P(AN/AA) copolymer films containing 10% AA dendrified with CA at first generation number (G1) heated at different temperatures for 10 min: (a) original (not heated), (b) 150°C , (c) 170°C , (d) 200°C , and (e) 220°C .

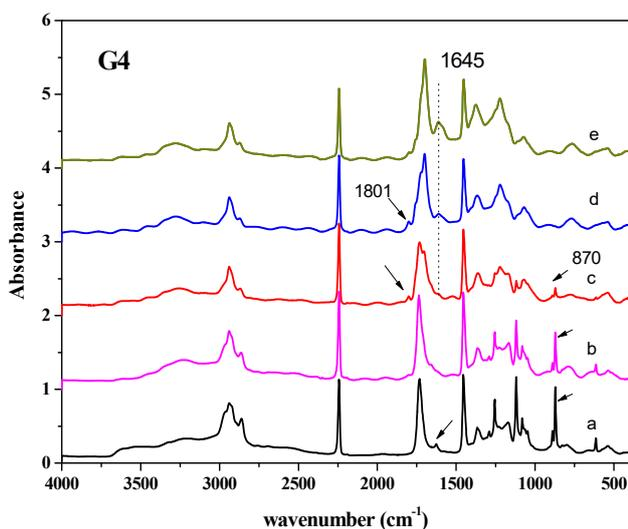
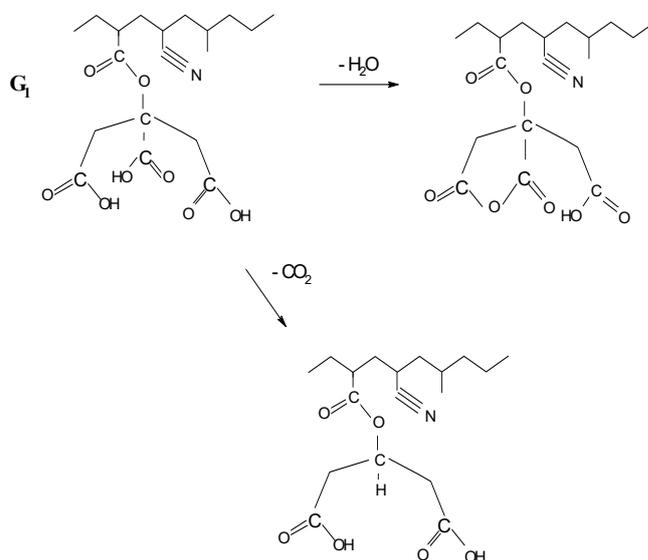

Fig. 3. FTIR spectra of the P(AN/AA) copolymer films containing 10% AA dendrified with CA at fourth generation number (G4) heated at different temperatures for 10 min: (a) original (not heated), (b) 150°C , (c) 170°C , (d) 200°C , and (e) 220°C .

B. Differential Scanning Calorimetry (DSC)

Fig. 4 shows the DSC curves of the P(AN/AA) copolymer films containing 10% AA ($10G_0$) heated at 5, 10 and $20^\circ\text{C}/\text{min}$ at air atmosphere, abbreviated with R5, R10 and R20, respectively. The DSC curves of other

samples were similar to the sample with 10% AA content ($10G_0$), which are not shown here. DSC measurements during the stabilization of P(AN/AA) show a distinct doublet exotherm; the one at lower temperature mainly attributed to the exothermic cyclization and the other attributed to the oxidative reactions [5,7].



Scheme 3. Proposed structure of P(AN/AA) copolymer dendrified with CA during thermal stabilization.

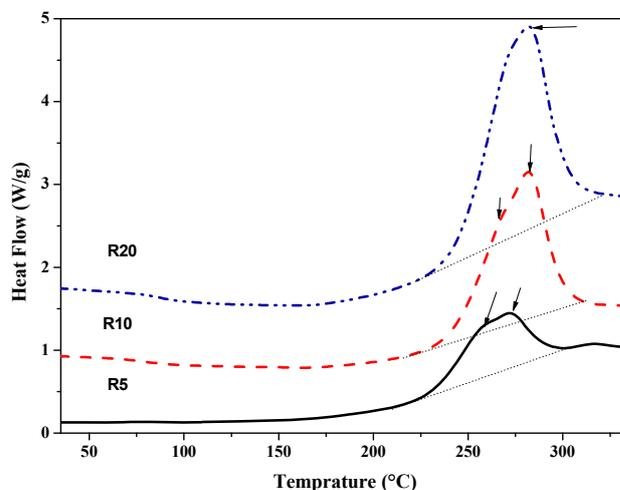

Fig. 4. DSC curves of P(AN/AA) copolymer films containing 10% AA (G_0) and dendrified with CA at first generation (G_1), heated at different heating rates: (a) $5^\circ\text{C}/\text{min}$ (R5), (b) $10^\circ\text{C}/\text{min}$ (R10), (c) $20^\circ\text{C}/\text{min}$ (R20).

As shown in Fig. 4, with increase in heating rate, the exotherms shift to a higher temperature, and the exothermic peaks become more and more strong, which is similar to the previous results [5]. By increasing the heating rate, the doublet character of the DSC exotherms corresponding to the sequence of cyclization and oxidation, turns into one peak. It seems that cyclization and oxidation reactions are now occurring simultaneously.

The DSC curves of P(AN/AA) copolymer films for $5G_0$, $10G_0$, and $20G_0$ heated at a heating rate of $10^\circ\text{C}/\text{min}$ are shown in Fig. 5. Following the nomenclatures used in the literature [22], the characteristics of the exothermic curves

TABLE II
PARAMETERS FROM DSC EXOTHERMS OF P(AN/AA) COPOLYMER CONTAINING 5, 10 AND 20 % AA AT DIFFERENT HEATING RATES

AA%	Rate 5 (°C/min)				Rate 10 (°C/min)				Rate 20 (°C/min)			
	T_i (°C)	T_f (°C)	T_{max} (°C)	ΔH (J/g)	T_i (°C)	T_f (°C)	T_{max} (°C)	ΔH (J/g)	T_i (°C)	T_f (°C)	T_{max} (°C)	ΔH (J/g)
5	200	300	270	284	211	309	282	376	228	324	293	423
10	191	302	267	307	202	312	276	348	216	331	295	349
20	183	306	260	295	194	317	274	291	208	334	288	225

TABLE III
PARAMETERS FROM DSC CURVES OF P(AN/AA) COPOLYMER DENDRIGRAFTED FILM CONTAINING 10% AA AT DIFFERENT HEATING RATES

#Generation	Rate 5 (°C/min)				Rate 10 (°C/min)				Rate 20 (°C/min)			
	T_i (°C)	T_f (°C)	T_{max} (°C)	ΔH (J/g)	T_i (°C)	T_f (°C)	T_{max} (°C)	ΔH (J/g)	T_i (°C)	T_f (°C)	T_{max} (°C)	ΔH (J/g)
G ₀	191	302	267	307	202	312	276	348	216	331	295	349
G ₁	186	302	258	355	206	314	281	413	213	336	292	426
G ₄	182	305	259	506	191	319	279	610	209	338	290	536

are designated by initiation temperature (T_i), maximum peak temperature (T_{max}), final temperature (T_f), and the total heat liberated (ΔH). Tables II and III show the characteristic parameters extracted from DSC curves at different heating rates for P(AN/AA) copolymers containing different amount of AA and dendrigrafted film. Accordingly, as the acid content of the copolymer increases the released heat decreases. Moreover, the related curves become broader with lower initiation temperature (T_i), and final peak temperature (T_f) as well as smaller ΔH , due to the different initiation mechanism and relatively much slower propagation rate of the cyclization reaction, which are in agreement with the literature [5,7,22]. For acrylonitrile-carboxylic acid copolymer, the initiation of cyclization reaction follows an ionic mechanism in comparison with radical mechanism suggested for acrylonitrile homopolymer [5].

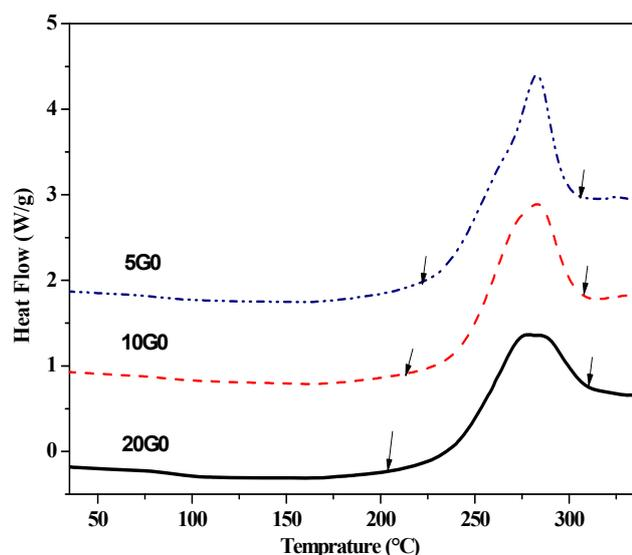

Fig. 5. DSC curves of P(AN/AA) copolymer films containing 5, 10, 20% AA, heated at the rate of 10°C/min.

In the previous publication [33] for the same polymer using NMR techniques, we have shown that by increasing the acidic comonomer, the isotacticity and the blocky character of the copolymers increase. It is also suggested

that the rate of cyclization depends on the sequence distribution of the comonomer in the acrylonitrile copolymers [22]. The lower T_i and ΔH values for higher AA content that we observed in the present work may be related to the increase in isotacticity, which tends to shorten the induction period in the thermal treatment of P(AN/AA).

The DSC curves of P(AN/AA) copolymer films containing 10%AA dendrigrafted with CA (10G1, 10G4), at a heating rate of 10 °C/min are illustrated in Fig. 6. The characteristic parameters obtained from DSC curves at different heating rates are listed in Table III. The results revealed that by increasing the generation number, the exotherm curves of samples become a little broader with lower initiation (T_i) and final peak (T_f) temperatures, while ΔH values increase considerably.

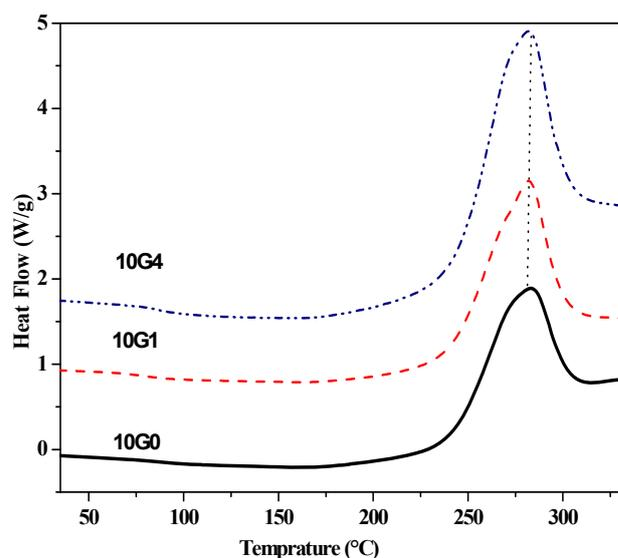

Fig. 6. DSC curves of the P(AN/AA) copolymer films containing 10% AA content (G0) dendrigrafted with CA at first (G1) and fourth (G4) generation number at a 10 °C/min heating rate.

According to the literature [5,17], acidic co-monomers promotes the thermo-oxidative stabilization. It seems that the role of carboxylic acid produced from acrylic acid in the bulk during copolymerization process differs from the

role of carboxylic acid generated in the dendrigraft formation. Having carboxylic acid in the bulk reduces the ΔH value due to the change in the mechanism of cyclization from radical mechanism to ionic catalyzed one [22]. However, the presence of carboxylic acid caused by the dendrigraft formation increases the ΔH value because of providing more opportunities for the interaction between carboxylic groups and nitrile groups.

It was demonstrated that the increase in ΔH is associated with the increase in the number of opportunities for the reactions [35]. Accordingly, the presence of more carboxylic acid groups on the surface of the present samples by dendrigraft formation increases the ΔH values.

C. Activation Energy

Differential isoconversional method was used to determine the activation energy of the reactions. Isoconversional principle states that the reaction at constant extent of conversion (α) is only a function of temperature, T . For linear non-isothermal procedures, the differential isoconversional method based on (1), [32] is used.

$$\ln \left[\beta_i \left(\frac{d\alpha}{dT} \right)_{\alpha,i} \right] = \ln [f(\alpha)A_\alpha] - \frac{E_\alpha}{RT_{\alpha,i}} \quad (1)$$

where E_α is the activation energy at each α , R is the universal gas constant, $\ln [f(\alpha)A_\alpha]$ is the intercept, β is the heating rate and the subscript i denote the individual heating rate. To calculate the activation energy (E_α) of the samples, first the values of α are calculated from (2).

$$\alpha = \frac{\Delta H_T}{\Delta H} \quad (2)$$

where ΔH_T and ΔH are the enthalpy from zero to T and the total enthalpy extracted from DSC exotherms, respectively. Fig. 7 shows the values of α against the temperature for the sample 10G0 heated with different rates of 5, 10, and 20°C/min. The trends of the extent of conversion (α) against the temperature for other samples are found to be similar to that for the 10G0, that are not shown here.

The value of E_α is obtained from (1). At each value of α , the value of E_α is determined from the slope of the plot of $\ln(d\alpha/dT)_{\alpha,i}$ against $1/T_{\alpha,i}$.

Fig. 8 reveals the activation energy against the extent of conversion for P(AN/AA) copolymer films containing 5, 10 and 20 % AA (5G₀, 10G₀ and 20G₀). Of particular interest is at the high extent of conversion for $\alpha > 0.4$, which is assigned to the cyclization and oxidation reactions. The value of E_α increases sharply for the samples with higher AA content presumably due to the ionic mechanism in thermal stabilization in the presence of acidic co-monomer, which is in agreement with the results of the previous published work [34].

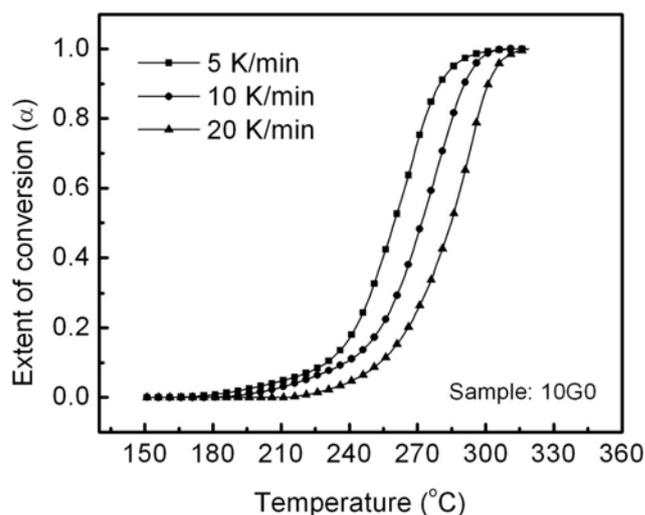

Fig. 7. Extent of conversion vs. temperature for P(AN/AA) copolymer films containing 10 % AA (10 G₀) at different heating rates of 5, 10 and 20 °C/min.

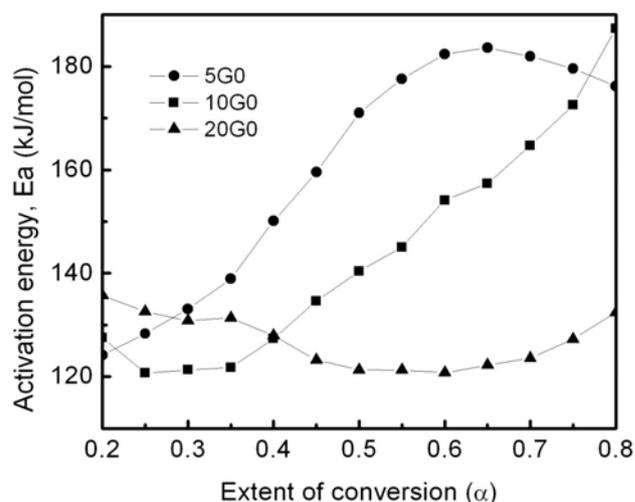

Fig. 8. Activation energy vs. extent of conversion for P(AN/AA) copolymer films containing 5, 10 and 20 % AA.

By increasing acidic comonomer, the isotacticity of the copolymers increase with a more randomness in the distribution of the co-monomers. More isotactic unit as well as blocky character may facilitate cyclization and oxidation reaction [34]. As a result, more AA content reduces E_α value of cyclization and oxidation reactions in the thermal treatment. Also, it is evident that the activation energy has been reduced by incorporation of itaconic acid as comonomer into PAN [5] which consists of two carboxylic acid groups comparing to one carboxylic acid group in acrylic and methacrylic acid.

The E_α value against α for P(AN/AA) copolymer films containing 10% AA dendrigrafted with CA at first (10G₁) and fourth (10G₄) generation numbers are illustrated in Fig. 9. Since the percentage conversion of the reaction of dendrigrafted formation was low (according to Table 1), the activation energies are close to each other. The E_α value of 10G₁ is lower than the other samples (10G₀, 10G₄) at the high extent of conversion for $\alpha > 0.4$. The lower E_α value of 10G₁ may be related to its "dense shell" dendritic

structure. Dense shell is formed in the first generation which has the lowest density. These are according to the de Gennes dense packed theory completely explained in the previous work [31].

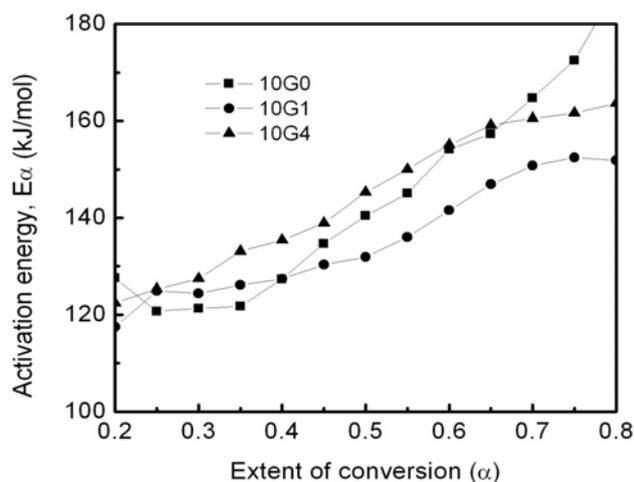

Fig. 9. Activation energy vs. extent of conversion for P(AN/AA) copolymer films containing 10% AA (10G₀) dendrigrated with CA at first (10G₁) and fourth (10G₄) generation numbers.

The activation energies of PAN copolymers for degradation reactions from various literatures are summarized in Table IV. Comparison of the activation energies (E_a) indicate that different methods and various temperatures lead to different values. The values of E_a obtained from the experiments in this work using the differential isoconversional method is in the range of the

other calculated activation energies.

The calculated activation energies indicate that the energy barrier of stabilization reactions of the first generation (10G₁) dendrigrated P(AN/AA) copolymer decreases while that of the 4th generation (10G₄) increases in comparison with the copolymer before dendrigrat formation (10G₀).

Often Kissinger method [36,32,17] has been applied to determine the activation energies. In this method it is assumed that the reaction rate is maximum. However, it can be used to quantify E_a without any prior knowledge of reaction mechanism, by just having a series of DSC curves at different heating rates [5,22,32]. Kissinger method produces a single value of the activation energy for any process regardless of its actual kinetic complexity, while the differential isoconversional method produces a range of E_a and A values [32].

Equation (3) is used to calculate the activation energies from Kissinger method, from the slope of the plot of

$$\ln\left(\frac{\beta}{T_{m,i}^2}\right) \text{ against } \frac{1}{T_{m,i}} \quad [36].$$

$$\ln\left(\frac{\beta}{T_{m,i}^2}\right) = \ln\left(-\frac{AR}{E} f'(\alpha_m)\right) - \frac{E}{RT_{m,i}} \quad (3)$$

where subscript m denote the values related to the maximum rate and $f'(\alpha) = \frac{d\alpha}{dt}$. Other symbols have the same meaning as in (1).

TABLE IV
ACTIVATION ENERGIES OF PAN COPOLYMERS FOR DEGRADATION REACTIONS FROM LITERATURE

Polymer	Method	reaction	E_a (KJ/mol) ^a	Ref.
PAN		Stabilization	123.7	
AN/IA (98.5/1.5)	DSC ^b	Cyclization	103.7	5
AN/IA (98.5/1.5)		Oxidation	117.6	
PAN/MA (95/5)	Shrinkage	oxidation and dehydrogenation	265.9	14
PAN/MA/IA (93/6/1)	DSC (Kissinger method)	Cyclization	125	
		dehydrogenation	108	15
		Oxidation	125	
PAN/AA (96.9/3.1)			184.8	
PAN/MAA (97.4/2.6)	DSC (Kissinger method)	Cyclization	123.3	22
PAN/IA (97.8/2.2)			109.1	
Commercial PAN with Small amount of MA/IA	DSC ^b		188.2	
	TMA ^b	Cyclization	182.7	17
	TG ^b		309.3	
PAN	DTA	Cyclization under N ₂	126.42	
		Cyclization under air	141.96	19
		Cyclization under N ₂	107.1	
PAN/MA (95/5)		Cyclization under air	111.72	
PAN	DSC		153.2	23
PAN/IA (98.5/1.5)		Cyclization at 175-200° C	110.3	

^a All E_a value have changed to KJ/mol

^b Kissinger and Ozawa method gives nearly identical values for each E_a and A . As a result, in this Table only the result of Kissinger method is shown.

Activation energies were calculated by Kissinger method. Table V indicate that the energy barrier for the reactions of 10G₁ is less than that of 10G₄ and that of the copolymer before dendrigraft formation (10G₀), which is similar to that calculated by isoconversional method.

TABLE V
THE E_a AND A VALUES DETERMINED BY THE KISSINGER METHOD

Sample	E _a (KJ/mol)	A(S ⁻¹)
5G ₀	146.97	4.02×10 ¹⁰
10G ₀	110.60	1.29×10 ⁷
20G ₀	110.72	1.72×10 ⁷
10G ₁	90.43	1.42×10 ⁵
10G ₄	100.55	1.50×10 ⁶

D. Thermogravimetric (TGA) and Derivative Thermogravimetric (DTG) Analysis

The TGA and DTG curves of the P(AN/AA) films containing 10%AA, 10G₀, under nitrogen as a purge gas are shown in Fig. 10 and the relevant parameters are summarized in Table VI. The TGA curves show the change of weight, while the DTA curves show the rate of different reactions taking place. The nature of these reactions has been documented in the literature [17-22]. The first step, up to 250°C, in which losing weight is not substantial, is followed by a second step (from 250 to 300°C) in which losing weight occurs rapidly. In the last step, above 350°C, the weight loss is quite steady [17]. The starting and ending temperature of different steps, depicted from TGA curves depends on the samples, the testing environment, the purity of purging nitrogen, and the heating rate.

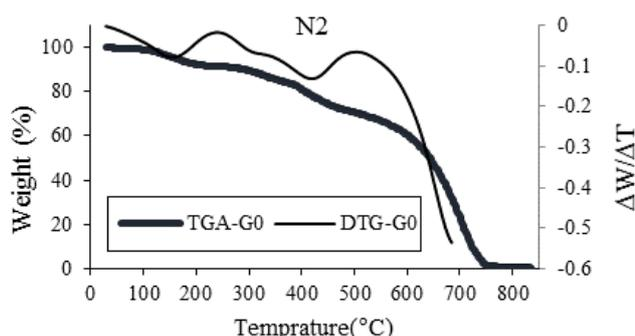

Fig. 10. TGA and DTGA curves of the P(AN/AA) film containing 10%AA, (G₀) under nitrogen purge.

TABLE VI
THE PERCENTAGE OF WEIGHT LOSS OF THE G₀ AND G₄ FILMS IN N₂ AND AIR ATMOSPHERES OBTAINED FROM TGA

Generation #	Atmosphere	weight loss % at different temperatures			
		300°C	400°C	500°C	600°C
G ₀	N ₂	10.5	19	29.4	39.7
G ₄	N ₂	15.5	23.1	33.9	81.1
G ₄	air	14	23	36.1	73.5

The TGA and DTA curves of the P(AN/AA) films containing 10% AA (10G₀) and the fourth generation of CA dendrigrafted on the P(AN/AA) films containing 10%

AA, 10G₄ under nitrogen purge and 10G₄ sample under air atmosphere are shown in Figs. 10, 11 and 12, respectively. Due to the different types of reactions taking place in the three steps, the DTA curves indicate three peaks in all Figures. Table VI shows the percentage of the weight loss of G₀ and G₄ films in N₂ and air atmospheres at different temperatures.

The TGA curves of these dendrigrafted copolymers under nitrogen purge show slightly different behavior from that of 10G₀. Furthermore, at 600°C the total weight loss of the samples in air is less than that in the nitrogen purge (Table VI), this is because in the air atmosphere oxidation reactions take place, which improves the weight retention. This is in agreement with the explanation [17] that the pyrolysis in the air results in a lesser weight loss than that in the nitrogen atmosphere. By other researchers [19], however, it has been shown that the activation energy for the cyclization reaction under N₂ is lower than that in the air atmosphere. Such controversial contradictions in results reconfirm the complexity of the nature of these reactions.

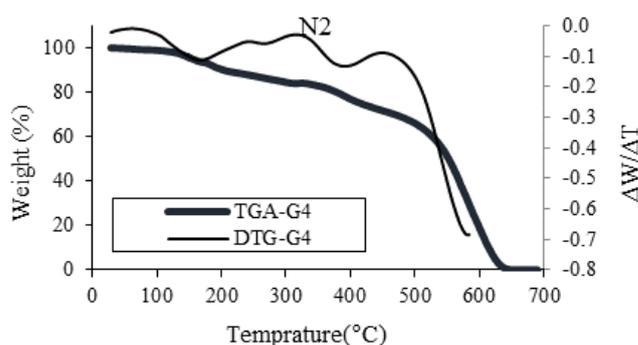

Fig. 11. TGA and DTGA curves of fourth generation of CA dendrigrafted on the P(AN/AA) film containing 10%AA (G₄) under nitrogen purge.

The TGA curves of the 10G₀ and 10G₄ show a steady region up to the second step in which the weight loss of both samples indicates a slightly different behavior. In the third step, the weight loss is fast, particularly for 10G₄. The total weight loss at 600°C is 39.65 % and 81.08% for 10G₀ and 10G₄, respectively. The greater and the faster rate of weight loss is due to rapid cyclization and decomposition of carboxylic groups on the surface. Furthermore, in previous sections it was shown that the presence of carboxylic acid in dendrigrafted structure leads to a higher ΔH value.

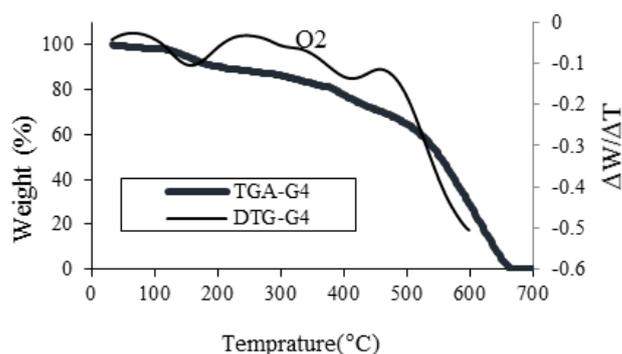

Fig. 12. TGA and DTGA curves of fourth generation of CA dendrigrafted on the P(AN/AA) film containing 10%AA, (G₄) in air.

IV. CONCLUSION

Thermal behavior of P(AN/AA) copolymer films containing 5, 10, and 20 % AA and also CA dendrigrated films containing 10 % AA at first and fourth generation numbers were studied using FTIR, DSC, TGA and DTG analyses. Analyses of the FTIR spectra of the films heated up to 220°C reveals that the stabilization reactions occur above 170°C, where the dendrigrated samples are stabilized in a ladder frame structure. During the degradation of the copolymer films in DSC, the oxidation reactions become less intense by increasing of AA content in the copolymer. The carboxylic acid groups in the bulk resulting from copolymerization process behave differently from the carboxylic acid groups generated during dendrigrade formation. The carboxylic acid in the bulk reduces the ΔH value, while the presence of carboxylic acid in the dendrigrade formation increases the value of ΔH . The apparent activation energies were determined with the help of differential isoconversional and Kissinger method. Since cyclization and oxidation process is a requisite process to produce stable ladder like molecular structure in the production of carbon fibers from PAN, the presence of carboxylic acid groups on the film can improve the cyclization and oxidation and even it modifies the thermal properties of the manufactured fibers. Modification to the first generation dendrigrade reduces thermal degradation reaction energy barriers.

Acknowledgements

We would like to thank Prof. S.H. Bahrami for many valuable discussions and collaborations. The authors are also grateful to Mrs. Mahmoodi, Dr. M. Radjabian and Mr. N. Rabiei from Analytical Laboratory, Textile Engineering Department, Amirkabir University of Technology, Tehran, Iran. We acknowledge the partial financial support of the Center of Excellence for Modern Textile (CENMIT).

REFERENCES

- [1] M. S. A. Rahaman, A. F. Ismail and A. Mustafa, "A review of heat treatment on polyacrylonitrile fiber", *Polym. Degrad. Stab.*, vol. 92, pp. 1421-1432, 2007.
- [2] Z. Bashir, "A critical review of the stabilisation of polyacrylonitrile", *Carbon*, vol. 29, pp. 1081-1090, 1991.
- [3] R. Cox, "Acrylic fibers", in: *Synthetic fibers nylon, polyester, acrylic, polyolefine*. ed by McIntyre JE, Woodhead Publishing Limited, Cambridge, England, 2005, pp. 167-234.
- [4] K. Sen, S. H. Bahrami and P. Bajaj, "High-performance acrylic fibers", *J. Macromol. Sci., Rev. Macromol. Chem. Phys.*, vol. 36, pp. 1-76, 1996.
- [5] Q. Ouyang, L. Cheng, H. Wang and K. Li, "Mechanism and kinetics of the stabilization reactions of itaconic acid-modified polyacrylonitrile", *Polym. Degrad. Stab.*, vol. 93, pp. 1415-1421, 2008.
- [6] J. S. Tsai and C. Hualin, "Effect of comonomer composition on the properties of polyacrylonitrile precursor and resulting carbon fiber", *J. Appl. Polym. Sci.* 43: 679-685, 1991.
- [7] K. A. Gupta, D. K. Paliwal and P. Bajaj, "Effect of an acidic comonomer on thermooxidative stabilization of polyacrylonitrile", *J. Appl. Polym. Sci.*, vol. 58, pp. 1161-1674, 1995.
- [8] I. F. C. Preta, S. K. Sakata, G. Garcia, J. P. Zimmermann, F. Galembek and C. Giovedi, "Thermal behavior of polyacrylonitrile polymers synthesized under different conditions and comonomer composition" *J. Therm. Anal. Calorim.*, vol. 87, pp. 657-659, 2007.
- [9] C. Cui, L. Yu and C. Wang, "The degradation and prestabilization of acrylonitrile copolymers", *J. Appl. Polym. Sci.*, vol. 117, pp. 1596-1600, 2010.
- [10] K.A. Gupta, D. K. Paliwal and P. Bajaj, "Melting behavior of acrylonitrile polymers", *J. Appl. Polym. Sci.*, vol. 70, pp. 2703-2709, 1998.
- [11] C. Hou, R. Qu, W. Qun and L. Ying, "Determination of degradation rate of acrylonitrile polymers", *J. Appl. Polym. Sci.*, vol. 101, pp. 1511-1514, 2006.
- [12] P. Bajaj, T. V. Sreekumar and K. Sen, "Thermal behaviour of acrylonitrile copolymers having methacrylic and itaconic acid comonomers", *Polymer*, vol. 42, pp. 1707-1718, 2001.
- [13] [13] A. K. Gupta, D. K. Paliwal and P. Bajaj, "Effect of the nature and mole fraction of acidic comonomer on the stabilization of polyacrylonitrile", *J. Appl. Polym. Sci.* vol. 59, pp. 1819-1826, 1996.
- [14] S. Soulis and J. Simitzis, "Thermomechanical behaviour of poly[acrylonitrile-co-(methyl acrylate)] fibres oxidatively treated at temperatures up to 180 °C", *Polym. Int.*, vol. 54, pp. 1474-1483, 2005.
- [15] K. Gupta and R. P. Singhal, "Effect of copolymerization and heat treatment on the structure and x-ray diffraction of polyacrylonitrile", *J. Polym. Sci., Part B: Polym. Phys.*, vol. 21, pp. 2243-2262, 1983.
- [16] J. Simitzis, and S. Soulis, "Correlation of chemical shrinkage of polyacrylonitrile fibres with kinetics of cyclization", *Polym. Int.*, vol. 57, pp. 99-105, 2008.
- [17] S. Xiao, H. Lv, Y. Tong, L. Xu and B. Chen, "Thermal behavior and kinetics during the stabilization of polyacrylonitrile precursor in inert gas", *J. Appl. Polym. Sci.*, vol. 122, pp. 480-488, 2011.
- [18] M. Yu, C. Wang, Y. Zhao, M. Zhang, W. Wang, "Thermal properties of acrylonitrile/itaconic acid polymers in oxidative and nonoxidative atmospheres", *J. Appl. Polym. Sci.*, vol. 116, pp. 1207-1212, 2010.
- [19] E. Fitzer and D. J. Müller, "The influence of oxygen on the chemical reactions during stabilization of PAN as carbon fiber precursor", *Carbon*, vol. 13, pp. 63-69, 1975.
- [20] E. Fitzer, W. Frohs and M. Heine, "Optimization of stabilization and carbonization treatment of PAN fibres and structural characterization of the resulting carbon fibres", *Carbon*, vol. 24, pp. 387-395, 1986.
- [21] N. Grassie and R. McGuchan, "Pyrolysis of polyacrylonitrile and related polymers-VI. Acrylonitrile copolymers containing carboxylic acid and amid structures", *Eur. Polym. J.*, vol. 8, pp. 257-269, 1972.
- [22] S. H. Bahrami, P. Bajaj and K. Sen, "Thermal behavior of acrylonitrile carboxylic acid copolymers", *J. Appl. Polym. Sci.*, vol. 88, pp. 685-698, 2003.
- [23] R. Devasia, C. P. Reghunadhan, P. Nair, B. K. Sivadasan and K. N. Ninan, "Cyclization reaction in poly(acrylonitrile/itaconic acid) copolymer: an isothermal differential scanning calorimetry kinetic study", *J. Appl. Polym. Sci.*, vol. 88, pp. 915-920, 2003.
- [24] J. J. Liu, H. Ge and C. G. Wang, "Modification of polyacrylonitrile precursors for carbon fiber via copolymerization of acrylonitrile with ammonium itaconate", *J. Appl. Polym. Sci.*, vol. 102, pp. 2175-2179, 2006.
- [25] S. J. Teertstra and M. Gauthier, "Dendrigrade polymers: macromolecular engineering on a mesoscopic scale", *Prog. Polym. Sci.*, vol. 29, pp. 277-327, 2004.
- [26] J. M. J. Frechet and D. A. Tomalia, "Dendrimers and other dendritic polymer", John-Wiley, Chichester, 2001.
- [27] F. Vogtle, S. Gestermann, R. Hesse, H. Schwierz and B. Windisch, "Functional dendrimers", *Prog. Polym. Sci.*, vol. 25, pp. 987-1041, 2000.
- [28] C. R. Yates and W. Hayes, "Synthesis and applications of hyperbranched polymers", *Euro. Polym. J.*, vol. 40, pp. 1257-1281, 2004.
- [29] S. Akbari, M. H. Kish and A. A. Entezami, "Copolymer of acrylonitrile/acrylic acid solid surface film dendrigrade with citric acid", *Polym. Int.*, vol. 57, pp. 846-853, 2008.
- [30] S. Akbari, M. H. Kish and A. A. Entezami, "Modification of acrylonitrile/acrylic acid copolymer films and fibers by dendrigrade Formation", *Polym. Int.*, vol. 59, pp. 1550-1557, 2010.
- [31] S. Akbari, M. H. Kish and A. A. Entezami, "Copolymer of acrylonitrile/acrylic acid film dendrigrade with citric acid: Host-guest properties of dendrigrade -dye complexes and the effects of acrylic acid content", *Iran. Polym. J.*, vol. 20, pp. 539-549, 2011.

- [32] S. Vyazovkina, A. K. Burnhamb, J. M. Criadoc, L. A. Pérez-Maquedac, C. Popescud and N. Sbirrazzuolie, "ICTAC Kinetics Committee recommendations for performing kinetic computations on thermal analysis data", *Thermochim. Acta.*, vol. 520, pp. 1-19, 2011.
- [33] S. Vyazovkin, K. Chrissafis, M. L. Di Lorenzo, N. Koga, M. Pijolat, B. Roduit, N. Sbirrazzuoli and J. J. Suñol, "ICTAC Kinetics Committee recommendations for collecting experimental thermal analysis data for kinetic computations", *Thermochim. Acta.*, vol. 590, pp. 1-23, 2014.
- [34] B. R. Reyhani, S. Akbari and M. H. Kish, "Dendrigraft with citric acid on acrylonitrile /acrylic acid copolymer-electrospun fibers", *Polym. Int.*, vol. 62, pp. 1767-1776, 2013.
- [35] K. Sen, P. Bajaj and T. V. Sreekumar, "Thermal behavior of drawn acrylic fibers", *J. Polym. Sci., Part B: Polym. Phys.*, vol. 41, pp. 2949-2958, 2003.
- [36] R. L. Blaine and H. E. Kissinger, "Homer Kissinger and the Kissinger equation", *Thermochim. Acta.*, vol. 540, pp. 1-6, 2012